



Ateliers de fabrication Saguenay inc

Leader in Quebec

Packing and packaging of garden produce

AGRICULTURAL DIVISION



Plastic Bagger KLW-2

**Design
Manufacture
Installation
Sale
Project Management**

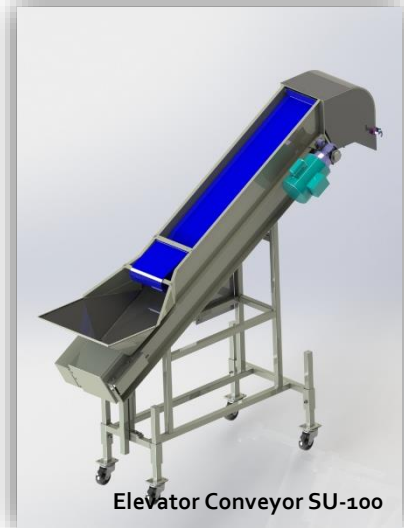

Elevator Conveyor SU-100



Paper Bag Making Machine
BP-100, BP-500 and BP-515

**Storing
Washing
Inspecting
Sorting
Packing
Calibrating
Packaging**



Packing of root and stem vegetables

Our agricultural equipment division is a leader in Quebec for packing and packaging of garden produce.

The **AFS** difference

- Expertise in design, custom manufacturing and installation
- Recognized expertise
- Product quality
- Great adaptability
- Outstanding customer service



OUR SERVICES

- Design engineering and manufacturing of a complete line of **packing** and **packaging** products and **custom products**.
- Design of state-of-the-art **instrumentation** and industrial **control** equipment.
- **Paint shop** and **sandblasting**.
- **Sale** and **installation** of our standard packing products and imported products.
- Sale of replacement parts.
- Sale of used equipment.

PERSONALIZED SERVICE TO MEET YOUR SPECIFIC NEEDS

Our representatives are available to assist you in your decision making process. As manufacturers, our personnel will advise you on possible scenarios to maximize your investment and avoid costly production errors.

OUR EXPERTISE AT YOUR SERVICE

We have a design service that will look at your plans on site, put them to scale, and then present a project that can help you in your decision making process. Thereafter, you will be able to go about your business, leaving the manufacturing of your equipment to us.

DESIGN-BUILD

AN INTEGRATED SERVICE!

Design, manufacturing and project management, all in one place!



Elevator Conveyor



Inspection Table



Bin Piler



Packaging Line



Telescopic Conveyor

STANDARD PACKING SYSTEMS

Packer, sewing system, inspection table, cylindrical washer, screen calibrator, felted or sponge table, reserve system, telescopic conveyor, floor conveyor, turntable, etc.

IMPORTED PRODUCTS

D.T. Dijkstra calibrator, Ilapak weigher, etc.



D.T. Dijkstra Calibrator

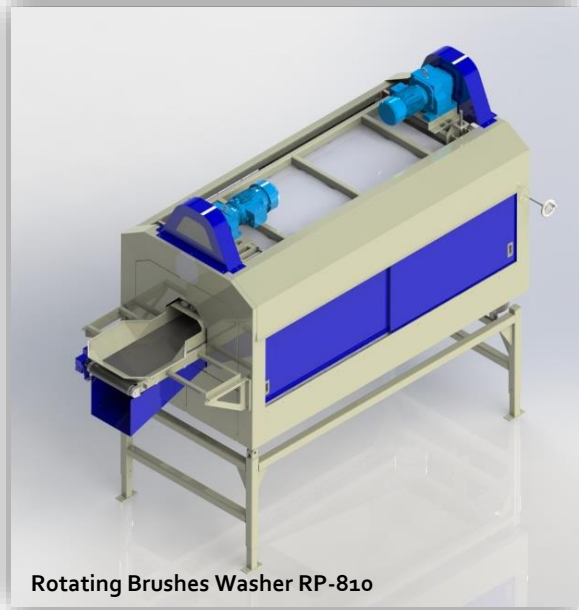

Rotating Brushes Washer RP-810

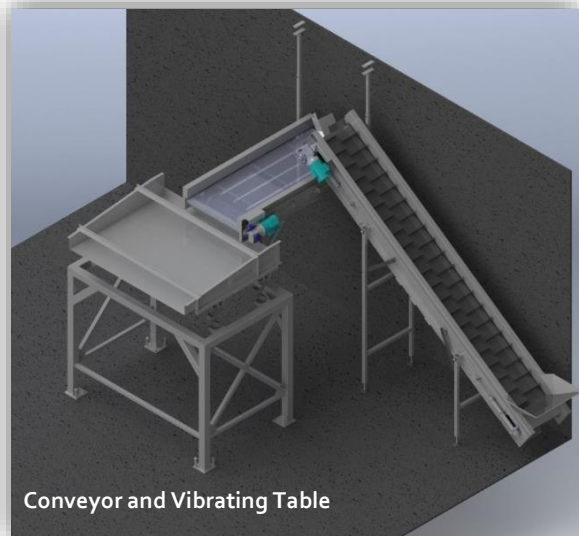

Conveyor and Vibrating Table

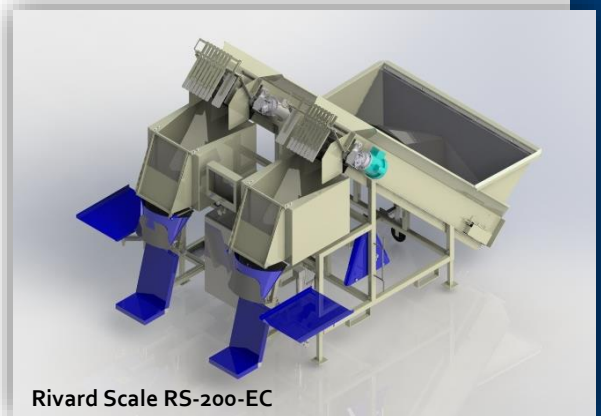

Rivard Scale RS-200-EC

Our **competent and versatile team** is at your service to design and manufacture custom products that meet your expectations.

We offer an integrated **design and manufacturing** service, including engineering and authentication of plans to reduce the number of stakeholders. Our engineers, drafters, welders-fitters, machinists, and quality inspectors will be able to understand your needs and **transform your ideas into concrete projects**.

Our project managers have several years of experience in the agricultural sector and in packing and processing plants. They will deliver **high-quality turnkey projects**.



Let us assist you in achieving your goals!

Our mission

AFS specializes in metal transformation in the industrial, agricultural and commercial domains, while providing flexibility to clients. Our team is comprised of qualified personnel who manufacture and install in a safe and secure manner:

- **Steel structures**
- **Metalworking**
- **Welded mechanical pieces**
- **Specialized pieces**
- **Conditioning equipment for garden produce.**

Our vision

AFS is recognized for designing, manufacturing and distributing of products and equipment that meet the requirements of clients and contribute to their product's quality and performance.

In order for the company to be a successful organization, we implement best practices in all areas of intervention.

Our customer approach

- Pursuing excellence
- Being trustworthy
- Acting as a partner and maintaining long-term relationships
- Delivering satisfaction
- Meeting deadlines

Health and Safety at AFS

We are committed to providing a healthy and safe work environment to our employees. For this reason, we are members of a prevention mutual and we have a H&S Committee, made up of workers who ensure maintenance and compliance with internal rules.



W47.1, division 2.1

Régie
du bâtiment

Québec 

RBQ 8235-0455-16

General and Specialised Entrepreneur

A TRADITION OF EXCELLENCE SINCE 1993

AFS

Ateliers de fabrication Saguenay inc

Two business sites :

1190, Rang 5, Saint-Ambroise (Québec) G7P 2E2
Tel. : 418 672-2154 | Fax : 418 672-4490

1685, rang des Chutes, Saint-Ambroise (Québec) G7P 2V5
Tel. : 418 672-2156 | Fax : 418 672-6795

afscanada.ca